

Fraunhofer Solution for Grid-Forming Inverter Developments and Innovative Ancillary Services Validation and Testing

A. Seibel, P. Unruh, T. Erckrath, R. Brandl, J. Steffen, M. Jung

Trends of the Energy Transition in Public Grids

- Shutdown of conventional power plants and integration of renewable energies for CO₂ reduction
- Sector coupling for efficient energy mix and storage
- Strong increase of inverters with additional requirements

Challenges for Power Electronics in Inverter-Dominated Grids

- Ensuring and extending security of supply and grid stability
- Replacing synchronous generators with appropriate inverters like grid-forming and grid-supporting inverters
- Compensation of reduced grid inertia due to the shutdown of conventional power plants
- Optimization / adaptation of grid codes
- Extension of stabilization functions, such as reactive power provision, active power balancing or reactions to grid faults
- Enhanced protection functions, such as brown / black start capability, grid protection systems, islanding detection

One Solution

Grid-forming control methods for inverters

- Grid-forming inverters offer possibilities for maintaining stable grid operation and increasing secure power supply even in grid-tied operation
- Flexibility through control parameter adaptations
- Grid forming properties even in overload situations with sufficient current limiting methods

Applications for laboratory tests

Figure 1 shows a Rapid Inverter Control Solution. The system simulates different applications like batteries, PV, Wind, charging solutions for electro mobility or power supply. The active frontend (inverter) is the connection to the physical setup for the grid-tied operation and emulates the system behavior. Even unbalanced grid controls can be realized due to the control of the neutral wire. For analyzing larger systems, interfaces to real-time computers are envisaged. Additional unique models and libraries with grid-forming control and sufficient current limitation are implemented for efficient test setups.

One Tool for Development

RICOSO | Rapid Inverter Control Solution for grid-forming inverters

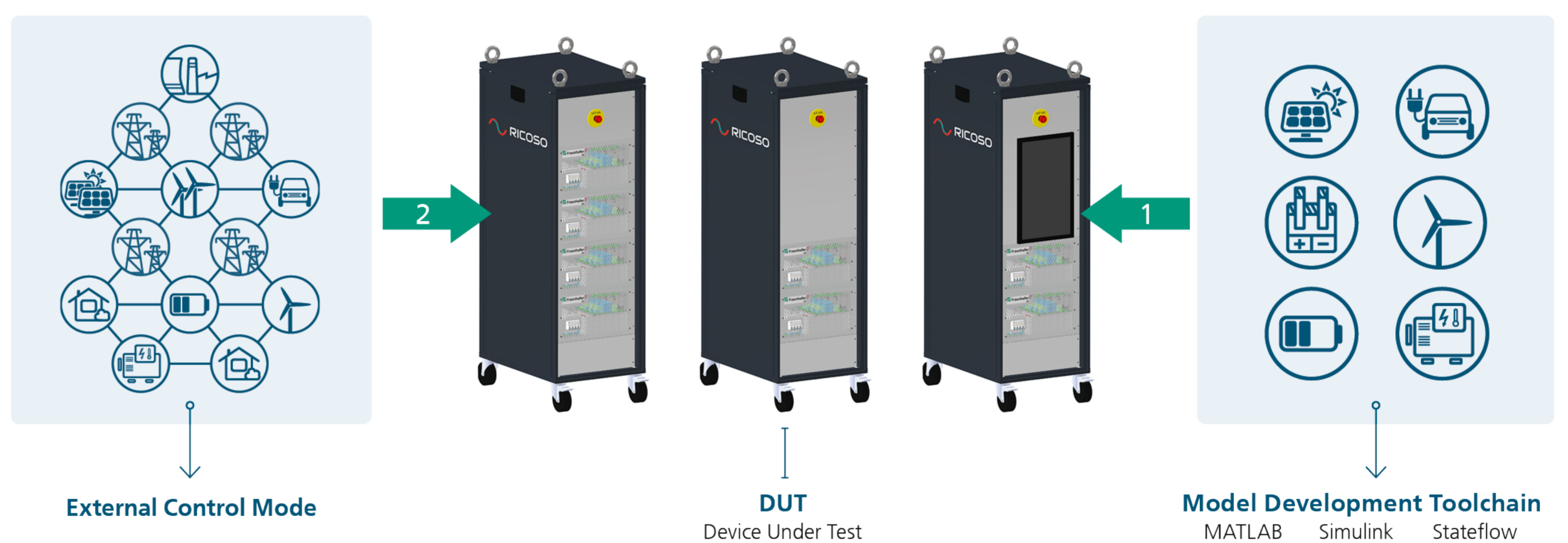

Figure 1: Practical development and research of control algorithms in laboratories
Path 1 direct programming; Path 2 external mode for larger system emulation

Drop Control and Parallel Operation for Grid-Forming Inverters

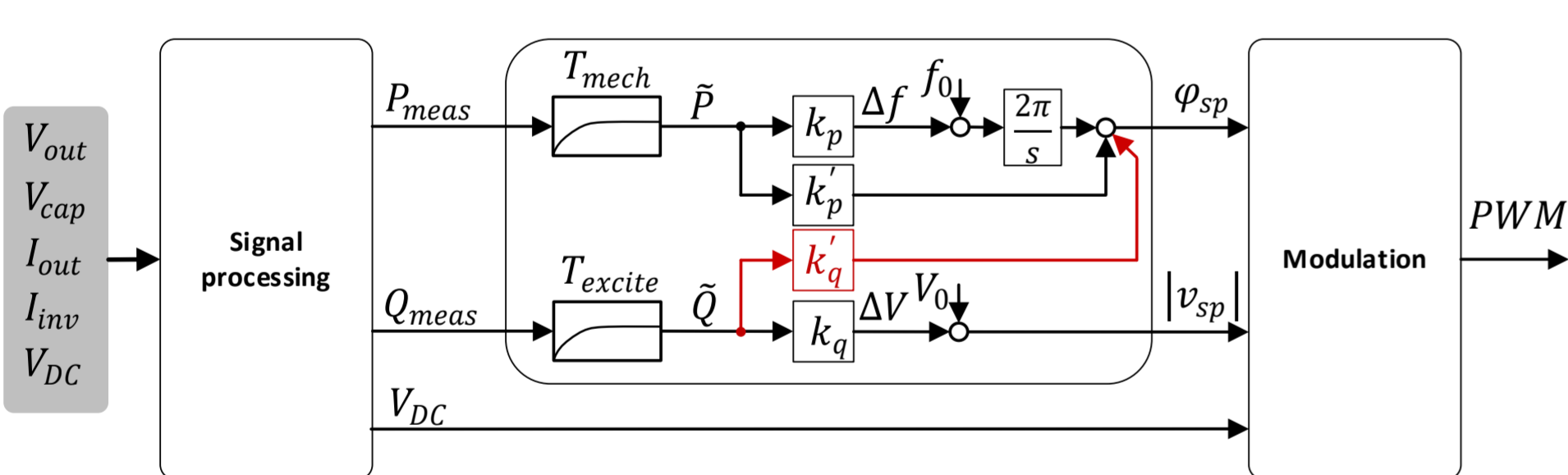

Figure 2: P. Unruh, T. Gühna, „Distributed grid-forming inverters in power grids“, in 7. Solar Integration Workshop

- Additional phase feedforward for predominantly resistive grids in spatial distribution
- Grid-Forming Inverters (GFM) with “small” output filter impedance
- Potential to decrease the need for additional decoupling inductors
- Higher cost efficiency of the hardware design
- Improved dynamic behavior

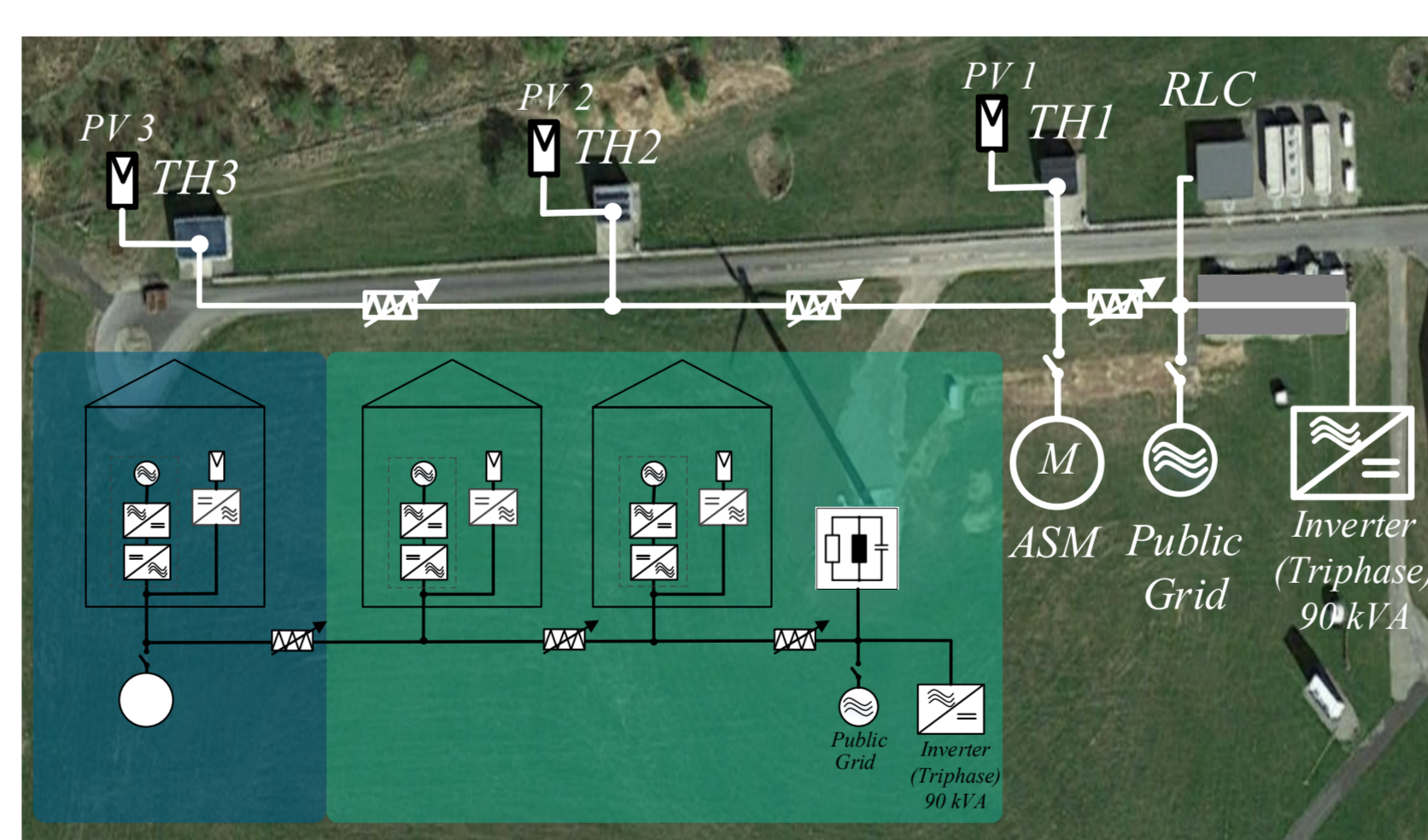

Figure 3: Test setup with three distributed GFM (2 x 43 kVA RICOSO, 1 x 90 kVA)

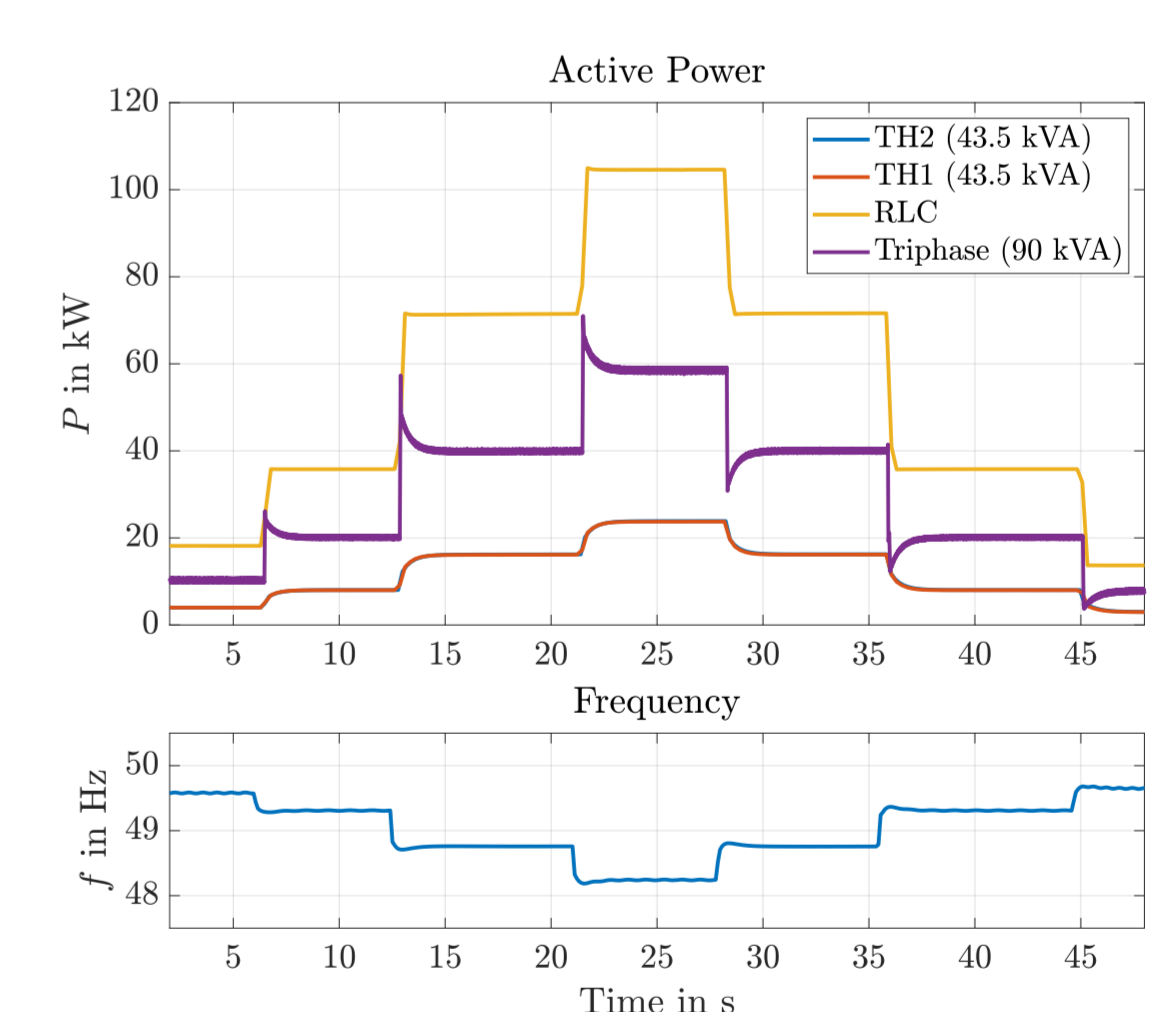

Figure 4: Power sharing due to load variation of distributed GFM and frequency response with drops

Property Rights Family

